

High Security Motorised Hook Lock

HL1260 INSTALLATION MANUAL



1. INTRODUCTION

The HL1260 is a motor driven Hook Lock which may be commonly installed vertically in the lock style of the door frame of a sliding door structure. A mechanical strike plate is normally installed in the edge of the sliding door to engage with the hook of the HL1260.

2. FEATURES

- Simple PTO/PTL Locking Mode changeover
- Small size

3. APPLICATIONS

The HL1260 Motorised Hook Lock can operate with any type of access control or intercom system as the sole means of locking, normally in a sliding door. The device is not weather resistant and therefore should always be installed in weather protected areas. The device should not be installed in pool areas and the like with a high content of chlorine in the air.

Two mounting options are available. In standard form the HL1260 is recess mounted into the door frame as shown above. Optionally available is a surface box kit available to suit both the lock and striking plate. They are supplied individually and accommodate either the lock or the striking plate.



4. TECHNICAL DATA

Power Input	11-30VDC
Power Consumption	Minimum 1A Regulated Power Supply recommended Locking/unlocking cycle current is 0.25 to 1A depending on the load. After locking/unlocking the current drops down to ~0.015A(15mA)
Monitoring switch specification	Bolt changeover switch 30VDC 0.1A Max Door position reed switch 30VDC 0.35A Max
Wiring Requirements PTL (Fail Safe)	Three Wire Configuration (Recommended) Black 0v Red Continuous Positive 11-30VDC Blue Access control. Connect to positive to activate the hook. Two Wire Configuration (Not Recommended) Black 0v Red and blue are connected together.
Wiring Requirements PTO (Fail Secure)	Three Wire Configuration (Recommended) Black 0v Red Continuous Positive 11-30VDC Blue Access control. Connect to positive to activate the hook. (Strike plate magnet must be present) Two Wire Configuration There is no 2 wire configuration for PTO (Fail Secure) operation
Wiring Bolt Position Monitoring (unlocked position)	White -(NO) Purple -(COM) Orange -(NC)
Wiring Door Position Monitoring	Green -Reed switch Green -Reed switch Normally Open, with door open The door has to be closed to activate the Door Position Monitoring. The lock has to be within 3mm to activate the DPS.
Durability	Meeting Australian Standard AS4145.2 - 2008 400.000 operating cycles Durability D7
Operating Temperature	-20 to +60 degree Celsius.
Maximum Door Gap	3mm between faceplate and strike plate.
Door Gap Adjustment	The activation gap between the door and frame is adjustable to compensate for varying door materials door
Mounting options	1. Recess mounted - as supplied with lock and strike plate 2. Surface Mount - Lock or strike plate fits into the surface mount box (HL1260BOX), two required for surface mounting lock and striking plate.
Certifications	CE, C-Tick,

5. ACCESSORIES AND ORDERING INFORMATION

Accessories	
HL1260-SM	Surface mount box (single) for HL1260 lock OR faceplate. NOTE: 2 required for full surface mounting option
Spare Parts	
HL1260-FP	Standard Strike Plate for HL1260

6. LOCKING MODE SETTING

The operation mode is set by a small changeover switch on the side of the lock. The default setting from the factory is Power to Lock (Fail Safe). If Power to Open (Fail Secure) is required, use the changeover switch to set the Locking Mode.

CAUTION — THE SWITCH IS FRAGILE.

BROKEN SWITCHES ARE NOT COVERED BY WARRANTY.

If the lock has been powered up, it may be necessary to either remove power to the lock for 5 minutes or cycle the lock once to ensure that the changeover has come into effect.



7. WIRING DIAGRAM

WIRING CONNECTIONS

11-30 VDC; 0.015 TO 1 Amp Max.

BLACK - 0 VDC
 BLUE - ACCESS CONTROL (SIGNAL)
 RED - POSITIVE (11-30VDC)

WHITE - — N.O. — BOLT POSITION MONITOR
 PURPLE - — COM. —
 ORANGE - — N.C. —

GREEN - — N.O. — DOOR POSITION MONITOR
 GREEN - — —

**THREE WIRE CONTROL
 RECOMMENDED FOR
 POWER CONNECTION**

8. INSTALLATION

a. Door Frame and Door preparation detail for Locking Device and Strike Plate

Before commencing with the installation ensure the gap between door and frame is less than 4mm

- Mark out the edge of the door to accommodate the striking plate using the dimensional drawing corresponding to centre line of Door
- Mark out the sliding door frame (usually a pocket) corresponding with the Door Frame

Note: Ensure both lock faceplate and striking plate will line up when the door is closed. The alignment pin on the lock faceplate must line up with the corresponding hole on the strike plate both in a horizontal and vertical plane.

Cut out a 22mm wide and 20mm deep cavity in the door behind the strike plate for the hook to be able to fully engage.

- Install the strike plate on the door, and lock in door frame. Ensure the door gap between the strike plate and the faceplate on the locking device is not more than 4mm **Note:** Thickness of strike plate & faceplate = 3mm

b. Installation of Locking Device and Strike Plate

- Ensure all wiring connections are correct and insulated, with no wires contacting any sharp edges.

Install the locking device into the door frame and strike plate on door as shown above.

Connect the device and apply power, allow the door to open and close normally. When the door closes and the magnet of the strike plate is line up within the locking range, the hook of the locking device will engage within the strike plate and lock the door.

c. Adjustment of Door Position Reed Switch

To ensure the hook engages when the gap between the lock and the strike plate is less than 3mm a reed switch is used. Different frame material may effect this sensing distance. In normal circumstances no adjustment is required, however an adjustment screw is incorporated in the striking plate. Turning this screw clockwise will reduce the detection gap between the door and frame, while an anticlockwise rotation will increase the gap. The turning of the screw moves a magnet towards or away from the sensor in the lock. The intention is to ensure the point of the hook does not hit the roller in the striking plate. The hook should pass behind the roller with the "ramp" of the hook able to slightly pull in the door if necessary

d. Notes

Locking device must only be used in weather protected areas

Locking device requires a strike plate to operate. It also requires the strike plate to correctly align with the lock faceplate•

9. PRODUCT CUT-OUT AND DIMENSIONS

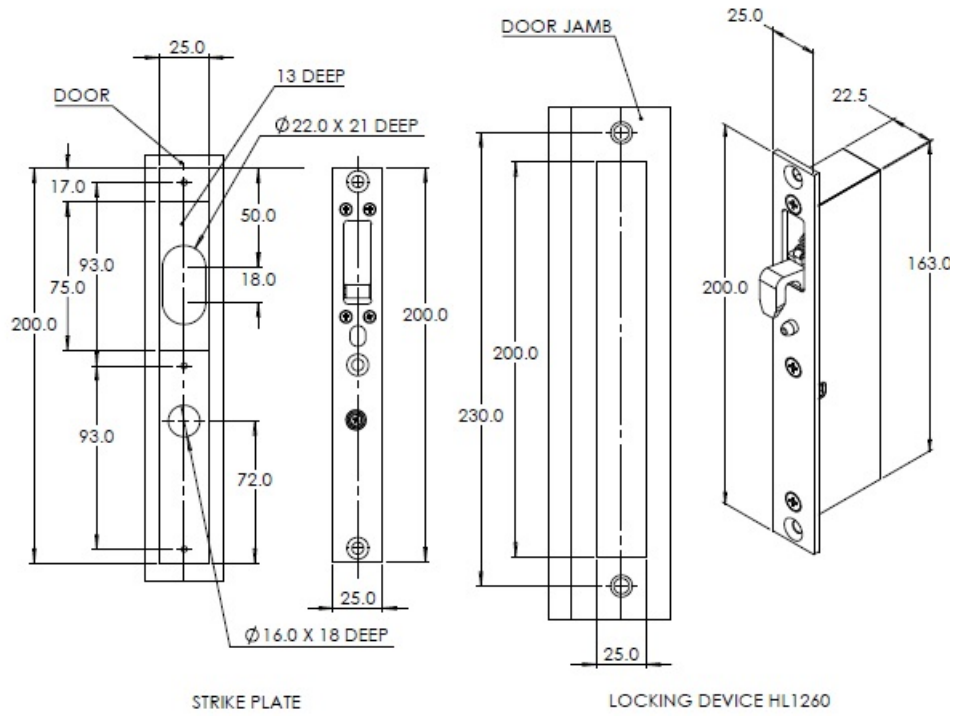

Locking Device HL1260 with optional HL1260-SM surface mount boxes (2)

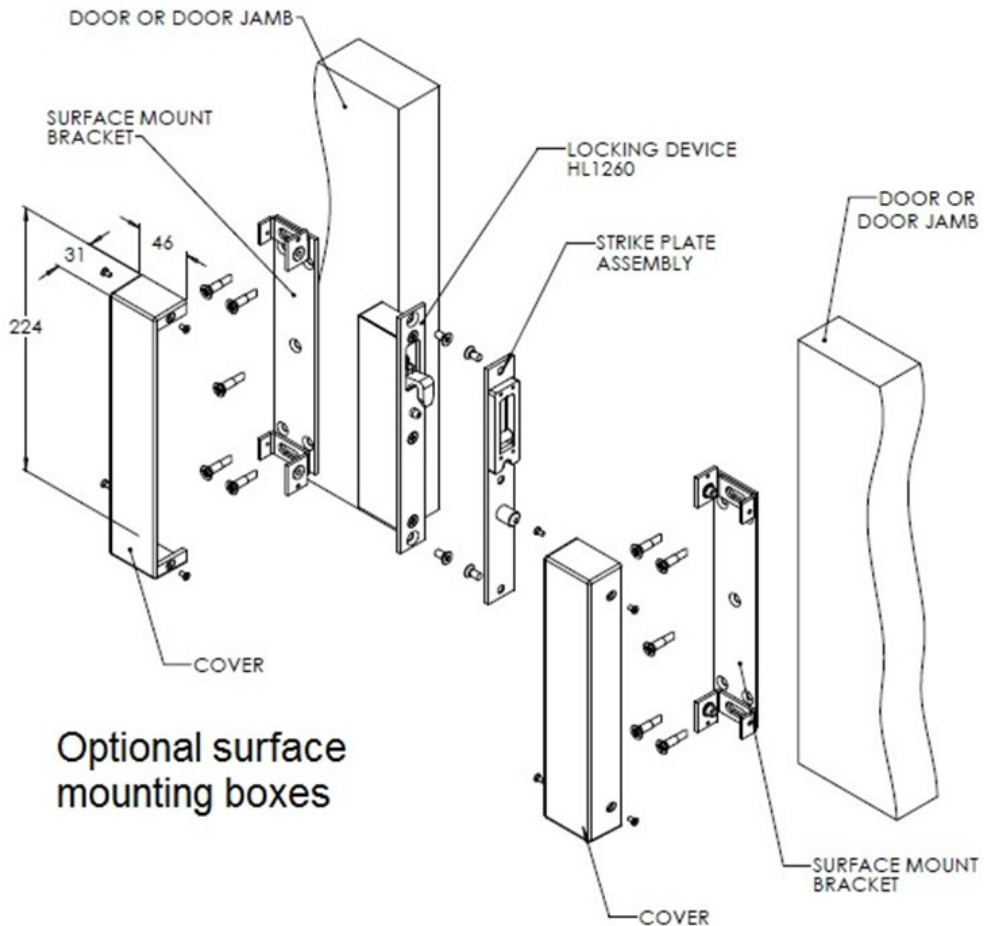

Optional surface mounting boxes